

Altivar 312

Installation manual

Variable speed drives
for asynchronous motors

DRAFT
09_03_06



Contents

Important Information	4
Before you begin	5
Documentation structure	7
Steps for setting up	8
Setup - Preliminary recommendations	9
Drive ratings	10
Single phase supply voltage: 200...240 V 50/60 Hz	10
Three phase supply voltage: 200...240 V 50/60 Hz	10
Three phase supply voltage: 380...500 V 50/60 Hz	11
Three phase supply voltage: 525...600 V 50/60 Hz	11
Dimensions and weights	12
Mounting	14
Mounting and temperature conditions	14
Removing the vent cover	14
Mounting types	14
Derating curves	15
Flow of air	15
Installing the EMC plates	16
Bus voltage measurement procedure	16
Wiring	17
Recommendations	17
General wiring diagram	18
Logic input switch	19
Power terminals	20
Control terminals	24
Electromagnetic compatibility (EMC)	26
Operation on an IT system	28
Check list	29
Maintenance	30
Recommended fuse ratings	31

Important Information

NOTICE

Read these instructions carefully, and look at the equipment to become familiar with the device before trying to install, operate, or maintain it. The following special messages may appear throughout this documentation or on the equipment to warn of potential hazards or to call attention to information that clarifies or simplifies a procedure.



The addition of this symbol to a Danger or Warning safety label indicates that an electrical hazard exists, which will result in personal injury if the instructions are not followed.



This is the safety alert symbol. It is used to alert you to potential personal injury hazards. Obey all safety messages that follow this symbol to avoid possible injury or death.

DANGER

DANGER indicates an imminently hazardous situation, which, if not avoided, **will result** in death or serious injury.

WARNING

WARNING indicates a potentially hazardous situation, which, if not avoided, **can result** in death, serious injury or equipment damage.

CAUTION

CAUTION indicates a potentially hazardous situation, which, if not avoided, **can result** in injury or equipment damage.

CAUTION

CAUTION, used without the safety alert symbol, indicates a potentially hazardous situation which, if not avoided, **can result** in equipment damage.

PLEASE NOTE

The word "drive" as used in this manual refers to the controller portion of the adjustable speed drive as defined by NEC.

Electrical equipment should be installed, operated, serviced, and maintained only by qualified personnel. No responsibility is assumed by Schneider Electric for any consequences arising out of the use of this product.

© 2009 Schneider Electric. All Rights Reserved

Before you begin

Read and understand these instructions before performing any procedure with this drive.

DANGER

HAZARD OF ELECTRIC SHOCK, EXPLOSION, OR ARC FLASH

- Read and understand this manual before installing or operating the Altivar 312 drive. Installation, adjustment, repair, and maintenance must be performed by qualified personnel.
- The user is responsible for compliance with all international and national electrical code requirements with respect to grounding of all equipment.
- Many parts of this drive, including the printed circuit boards, operate at the line voltage. DO NOT TOUCH. Use only electrically insulated tools.
- DO NOT touch unshielded components or terminal strip screw connections with voltage present.
- DO NOT short across terminals PA/+ and PC/- or across the DC bus capacitors.
- Before servicing the drive:
 - Disconnect all power, including external control power that may be present.
 - Place a "DO NOT TURN ON" label on all power disconnects.
 - Lock all power disconnects in the open position.
 - WAIT 15 MINUTES to allow the DC bus capacitors to discharge. Then follow the "Bus Voltage Measurement Procedure" page [16](#) to verify that the DC voltage is less than 42 V. The drive LEDs are not indicators of the absence of DC bus voltage.
- Install and close all covers before applying power or starting and stopping the drive.

Failure to follow these instructions will result in death or serious injury.

DANGER

UNINTENDED EQUIPMENT OPERATION

- Read and understand this manual before installing or operating the Altivar 312 drive.
- Any changes made to the parameter settings must be performed by qualified personnel.

Failure to follow these instructions will result in death or serious injury.

WARNING

DAMAGED DRIVE EQUIPMENT

Do not operate or install any drive or drive accessory that appears damaged.

Failure to follow these instructions can result in death, serious injury, or equipment damage.

WARNING

LOSS OF CONTROL

- The designer of any control scheme must consider the potential failure modes of control paths and, for certain critical control functions, provide a means to achieve a safe state during and after a path failure. Examples of critical control functions are emergency stop and overtravel stop.
- Separate or redundant control paths must be provided for critical control functions.
- System control paths may include communication links. Consideration must be given to the implications of unanticipated transmission delays or failures of the link.^a

Failure to follow these instructions can result in death, serious injury, or equipment damage.

a. For additional information, refer to NEMA ICS 1.1 (latest edition), "Safety Guidelines for the Application, Installation, and Maintenance of Solid State Control" and to NEMA ICS 7.1 (latest edition), "Safety Standards for Construction and Guide for Selection, Installation and Operation of Adjustable-Speed Drive Systems."

Before you begin

CAUTION

INCOMPATIBLE LINE VOLTAGE

Before turning on and configuring the drive, ensure that the line voltage is compatible with the supply voltage range shown on the drive nameplate. The drive may be damaged if the line voltage is not compatible.

Failure to follow these instructions can result in injury or equipment damage.

CAUTION

RISK OF DAMAGE TO THE MOTOR

The use of external overload protection is required under the following conditions:

- Repowering up the product since there is no motor thermal state memory.
- Running multiple motors.
- Running motors rated at less than 0.2 times the nominal drive current.
- Using motor switching.

Failure to follow these instructions can result in equipment damage

Documentation structure

The following Altivar 312 technical documents are available on the Schneider Electric website (www.schneider-electric.com) as well as on DVD-ROM (reference VW3A8200).

Installation manual

This manual describes how to install and wire the drive.

Programming manual

This manual describes the functions, parameters and use of the drive terminal (integrated display terminal, optional graphic display terminal and optional remote terminal).

Simplified manual

This manual is an extract from programming and installation manual. This manual is delivered with the drive.

Quick Start

The Quick Start describes how to wire and configure the drive to start motor quickly and simply for simple applications. This document is delivered with the drive.

Communication manuals: Modbus, CANopen, ...

These manual describes the assembly, connection to the bus or network, signaling, diagnostics, and configuration of the communication-specific parameters.

They also describe the protocol communication services.

INSTALLATION

1. Receive and inspect the drive

- Check that the catalog number printed on the label is the same as that on the purchase order.
- Remove the Altivar from its packaging and check that it has not been damaged in transit.

2. Check the line voltage

- Check that the voltage range of the drive is compatible with the line voltage (see pages [10](#) and [11](#)).

3. Mount the drive

- Mount the drive in accordance with the instructions in this document (see page [14](#)).
- Install any options required (see option documentation).

4. Wire the drive (see page [17](#))

- Connect the motor, ensuring that its connections correspond to the voltage.
- Connect the line supply, after making sure that the power is off.
- Connect the control part.

Steps 2 to 4 must be performed with the **power off**.



PROGRAMMING

5. Please refer to the programming manual.

Setup - Preliminary recommendations

Prior to switching on the drive

DANGER

UNINTENDED EQUIPMENT OPERATION

Ensure that all logic inputs are inactive to help prevent an accidental startup.

Failure to follow these instructions will result in death or serious injury.

Prior to configuring the drive

DANGER

UNINTENDED EQUIPMENT OPERATION

- Read and understand this manual before installing or operating the Altivar 312 drive.
- Any changes made to the parameter settings must be performed by qualified personnel.
- Ensure that all logic inputs are inactive to help prevent an accidental startup when modifying parameters.

Failure to follow these instructions will result in death or serious injury.

Line contactor

CAUTION

RISK OF DAMAGE TO THE DRIVE

- Avoid operating the contactor frequently to avoid premature aging of the filter capacitors.
- Power cycling must be more than 60 seconds.

Failure to follow these instructions can result in equipment damage.

Drive ratings

Single phase supply voltage: 200...240 V 50/60 Hz

For three phase output 200/240 V motors

Motor		Line supply (input)					Drive (output)		Reference	Size
Power indicated on plate (1)		Max. current line (2)		Apparent power	Max. inrush current (3)	Power dissipated at nominal current	Nominal current (1)	Max. transient current (1) (4)		
kW	HP	at 200 V	at 240 V						kVA	A
0.18	0.25	3.0	2.5	0.6	10	24	1.5	2.3	ATV312H018M2(5)	3
0.37	0.5	5.3	4.4	1.0	10	41	3.3	5.0	ATV312H037M2(5)	3
0.55	0.75	6.8	5.8	1.4	10	46	3.7	5.6	ATV312H055M2(5)	4
0.75	1	8.9	7.5	1.8	10	60	4.8	7.2	ATV312H075M2(5)	4
1.1	1.5	12.1	10.2	2.4	19	74	6.9	10.4	ATV312HU11M2(5)	6
1.5	2	15.8	13.3	3.2	19	90	8.0	12.0	ATV312HU15M2(5)	6
2.2	3	21.9	18.4	4.4	19	123	11.0	16.5	ATV312HU22M2(5)	7

Three phase supply voltage: 200...240 V 50/60 Hz

For three phase output 200/240 V motors

Motor		Line supply (input)					Drive (output)		Reference	Size
Power indicated on plate (1)		Max. current line (2)		Apparent power	Max. inrush current (3)	Power dissipated at nominal current	Nominal current (1)	Max. transient current (1) (4)		
kW	HP	at 200 V	at 240 V						kVA	A
0.18	0.25	2.1	1.9	0.7	10	23	1.5	2.3	ATV312H018M3	1
0.37	0.5	3.8	3.3	1.3	10	38	3.3	5.0	ATV312H037M3	1
0.55	0.75	4.9	4.2	1.7	10	43	3.7	5.6	ATV312H055M3	2
0.75	1	6.4	5.6	2.2	10	55	4.8	7.2	ATV312H075M3	2
1.1	1.5	8.5	7.4	3.0	10	71	6.9	10.4	ATV312HU11M3	5
1.5	2	11.1	9.6	3.8	10	86	8.0	12.0	ATV312HU15M3	5
2.2	3	14.9	13.0	5.2	10	114	11.0	16.5	ATV312HU22M3	6
3	3	19.1	16.6	6.6	19	146	13.7	20.6	ATV312HU30M3	7
4	5	24	21.1	8.4	19	180	17.5	26.3	ATV312HU40M3	7
5.5	7.5	36.8	32.0	12.8	23	292	27.5	41.3	ATV312HU55M3	8
7.5	10	46.8	40.9	16.2	23	388	33.0	49.5	ATV312HU75M3	8
11	15	63.5	55.6	22.0	93	477	54.0	81.0	ATV312HD11M3	9
15	20	82.1	71.9	28.5	93	628	66.0	99.0	ATV312HD15M3	9

(1) These power ratings and currents are for a maximum ambient temperature of 50°C and a switching frequency of 4 kHz in continuous operation. The switching frequency is adjustable from 2 to 16 kHz.

Above 4 kHz, the drive will reduce the switching frequency in the event of excessive temperature rise. The temperature rise is controlled by a sensor in the power module. Nonetheless, the nominal drive current should be derated if operation above 4 kHz needs to be continuous.

Derating curves are shown on page 15 as a function of switching frequency, ambient temperature and mounting conditions.

(2) Current on a line supply with the "Max. prospective line I_{sc} " indicated.

(3) Peak current on power-up, for the max. voltage (240 V + 10%).

(4) For 60 seconds.

(5) These references can be ordered without terminal board in order to integrate an optional communication board. Add a B at the end of the reference. For example, ATV312HU11M2 becomes ATV312HU11M2B.

Drive ratings (continued)

Three phase supply voltage: 380...500 V 50/60 Hz

For three phase output 380/500 V motors

Motor		Line supply (input)					Drive (output)		Reference	Size
Power indicated on plate (1)		Max. current line (2)		Apparent power	Max. inrush current (3)	Power dissipated at nominal current	Nominal current (1)	Max. transient current (1) (4)		
kW	HP	at 380 V	at 500 V							
		A	A	kVA	A	W	A	A		
0.37	0.5	2.2	1.7	1.5	10	32	1.5	2.3	ATV312H037N4(5)	6
0.55	0.75	2.8	2.2	1.8	10	37	1.9	2.9	ATV312H055N4(5)	6
0.75	1	3.6	2.7	2.4	10	41	2.3	3.5	ATV312H075N4(5)	6
1.1	1.5	4.9	3.7	3.2	10	48	3.0	4.5	ATV312HU11N4(5)	6
1.5	2	6.4	4.8	4.2	10	61	4.1	6.2	ATV312HU15N4(5)	6
2.2	3	8.9	6.7	5.9	10	79	5.5	8.3	ATV312HU22N4(5)	7
3	3	10.9	8.3	7.1	10	125	7.1	10.7	ATV312HU30N4(5)	7
4	5	13.9	10.6	9.2	10	150	9.5	14.3	ATV312HU40N4(5)	7
5.5	7.5	21.9	16.5	15.0	30	232	14.3	21.5	ATV312HU55N4(5)	8
7.5	10	27.7	21.0	18.0	30	269	17.0	25.5	ATV312HU75N4(5)	8
11	15	37.2	28.4	25.0	97	397	27.7	41.6	ATV312HD11N4(5)	9
15	20	48.2	36.8	32.0	97	492	33.0	49.5	ATV312HD15N4(5)	9

Three phase supply voltage: 525...600 V 50/60 Hz

For three phase output 525/600 V motors

Motor		Line supply (input)					Drive (output)		Reference	Size
Power indicated on plate (1)		Max. current line (2)		Apparent power	Max. inrush current (3)	Power dissipated at nominal current	Nominal current (1)	Max. transient current (1) (4)		
kW	HP	at 525 V	at 600 V							
		A	A	kVA	A	W	A	A		
0.75	1	2.8	2.4	2.5	12	36	1.7	2.6	ATV312H075S6(6)	6
1.5	2	4.8	4.2	4.4	12	48	2.7	4.1	ATV312HU15S6(6)	6
2.2	3	6.4	5.6	5.8	12	62	3.9	5.9	ATV312HU22S6(6)	7
4	5	10.7	9.3	9.7	12	94	6.1	9.2	ATV312HU40S6(6)	7
5.5	7.5	16.2	14.1	15.0	36	133	9.0	13.5	ATV312HU55S6(6)	8
7.5	10	21.3	18.5	19.0	36	165	11.0	16.5	ATV312HU75S6(6)	8
11	15	27.8	24.4	25.0	117	257	17.0	25.5	ATV312HD11S6(6)	9
15	20	36.4	31.8	33.0	117	335	22.0	33.0	ATV312HD15S6(6)	9

(1) These power ratings and currents are for a maximum ambient temperature of 50°C and a switching frequency of 4 kHz in continuous operation. The switching frequency is adjustable from 2 to 16 kHz.

Above 4 kHz, the drive will reduce the switching frequency in the event of excessive temperature rise. The temperature rise is controlled by a sensor in the power module. Nonetheless, the nominal drive current should be derated if operation above 4 kHz needs to be continuous.

Derating curves are shown on page 15 as a function of switching frequency, ambient temperature and mounting conditions.

(2) Current on a line supply with the "Max. prospective line I_{sc}" indicated.

(3) Peak current on power-up, for the max. voltage (500 V + 10%, 600 V + 10%).

(4) For 60 seconds.

(5) These references can be ordered without terminal board in order to integrate an optional communication board. Add a B at the end of the reference. For example, ATV312H037N4 becomes ATV312H037N4B.

(6) The use of an AC choke, which must be ordered separately (please refer to the catalog), is mandatory on these drives

Dimensions and weights

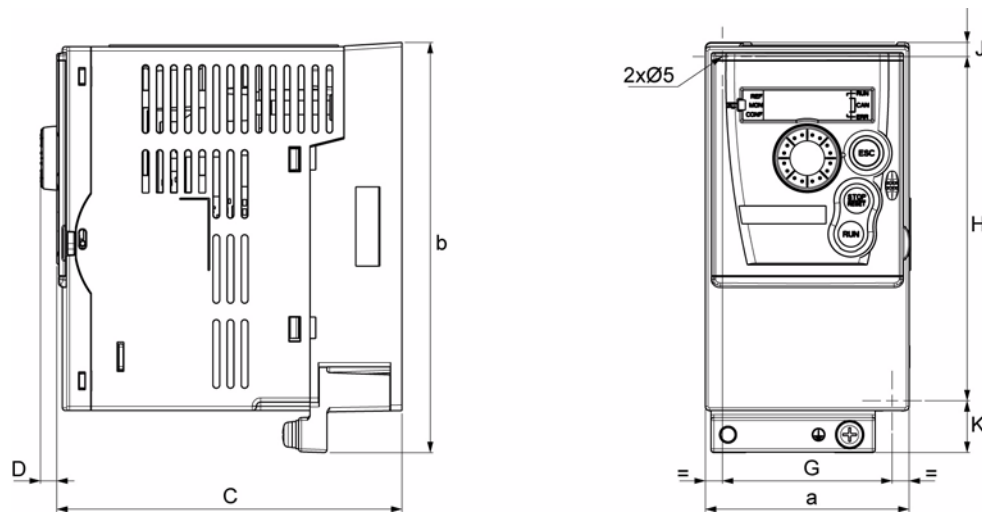

ATV312H	a mm (in.)	b mm (in.)	C mm (in.)	D mm (in.)	G mm (in.)	H mm (in.)	J mm (in.)	K mm (in.)	Ø mm (in.)
018M3, 037M3	72 (2.83)	145 (5.70)	122 (4.80)	6 (0.24)	60 (2.36)	121.5 (4.76)	2 x 5 (2x0.2)	18.5 (0.73)	2 x 5 (2x0.2)
055M3, 075M3	72 (2.83)	145 (5.70)	132 (5.19)	6 (0.24)	60 (2.36)	121.5 (4.76)	2 x 5 (2x0.2)	18.5 (0.73)	2 x 5 (2x0.2)
018M2, 037M2	72 (2.83)	145 (5.70)	132 (5.19)	6 (0.24)	60 (2.36)	121.5 (4.76)	2 x 5 (2x0.2)	18.5 (0.73)	2 x 5 (2x0.2)
055M2, 075M2	72 (2.83)	145 (5.70)	142 (5.59)	6 (0.24)	60 (2.36)	121.5 (4.76)	2 x 5 (2x0.2)	18.5 (0.73)	2 x 5 (2x0.2)

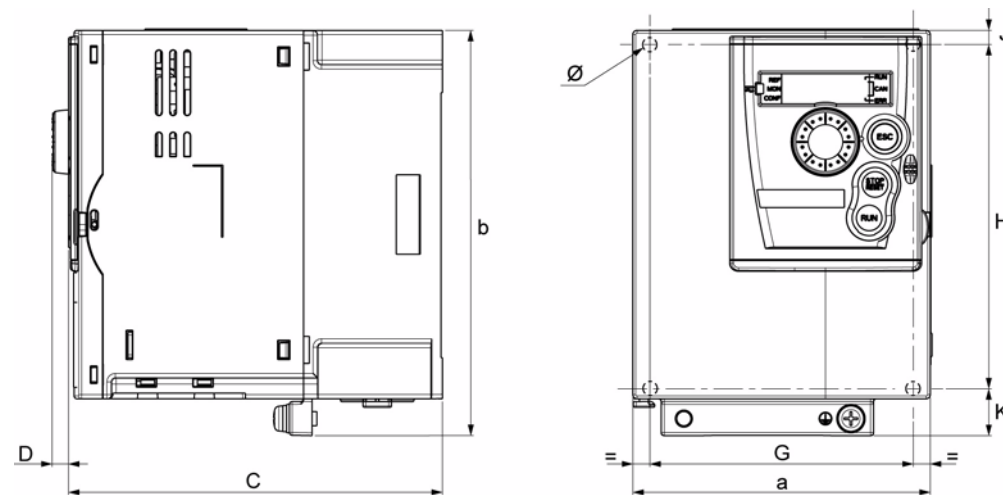

ATV312H	a mm (in.)	b mm (in.)	C mm (in.)	D mm (in.)	G mm (in.)	H mm (in.)	J mm (in.)	K mm (in.)	Ø mm (in.)
U1●M3	105 (4.13)	143 (5.63)	132 (5.19)	6 (0.24)	93 (3.66)	121.5 (4.76)	5 (0.2)	16.5 (0.65)	2 x 5 (2x0.2)
U1●M2, U22M3, 037N4 to U15N4 075S6, U15S6●	107 (4.21)	143 (5.63)	152 (5.98)	6 (0.24)	93 (3.66)	121.5 (4.76)	5 (0.2)	16.5 (0.65)	2 x 5 (2x0.2)
U22M2, U●0M3, U22N4 to U40N4, U22S6, U40S6	142 (5.59)	184 (7.24)	152 (5.98)	6 (0.24)	126 (4.96)	157 (6.18)	6.5 (0.26)	20.5 (0.81)	4 x 5 (4x0.2)

Dimensions and weights (continued)

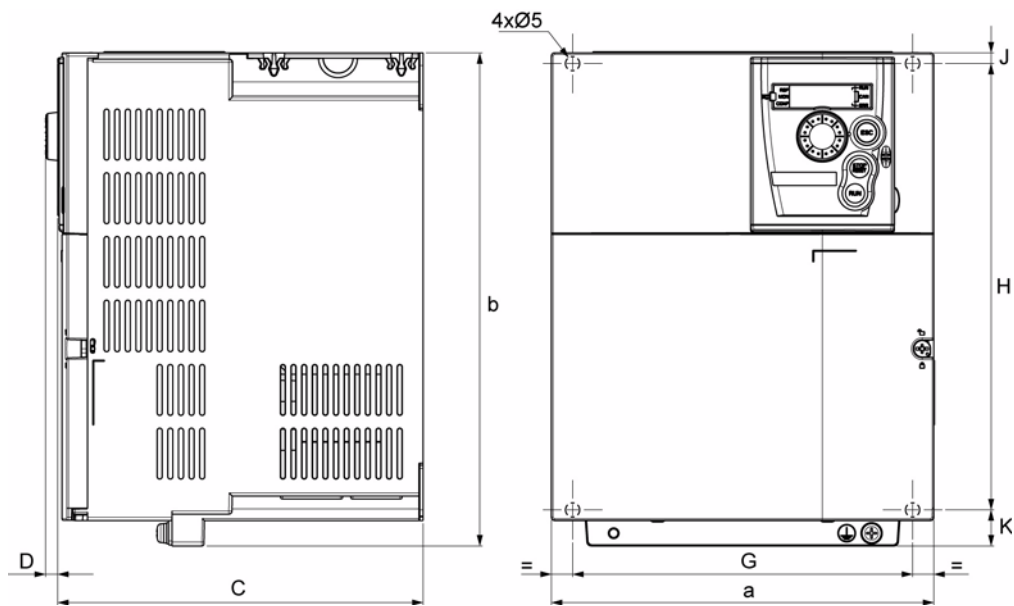

ATV312H	a mm (in.)	b mm (in.)	C mm (in.)	D mm (in.)	G mm (in.)	H mm (in.)	J mm (in.)	K mm (in.)	Ø mm (in.)
U55M3, U75M3, U55N4, U75N4, U55S6, U75S6	180 (7.09)	232 (9.13)	172 (6.77)	6 (0.24)	160 (6.30)	210 (8.27)	5 (0.2)	17 (0.67)	4 x 5 (4x0.2)

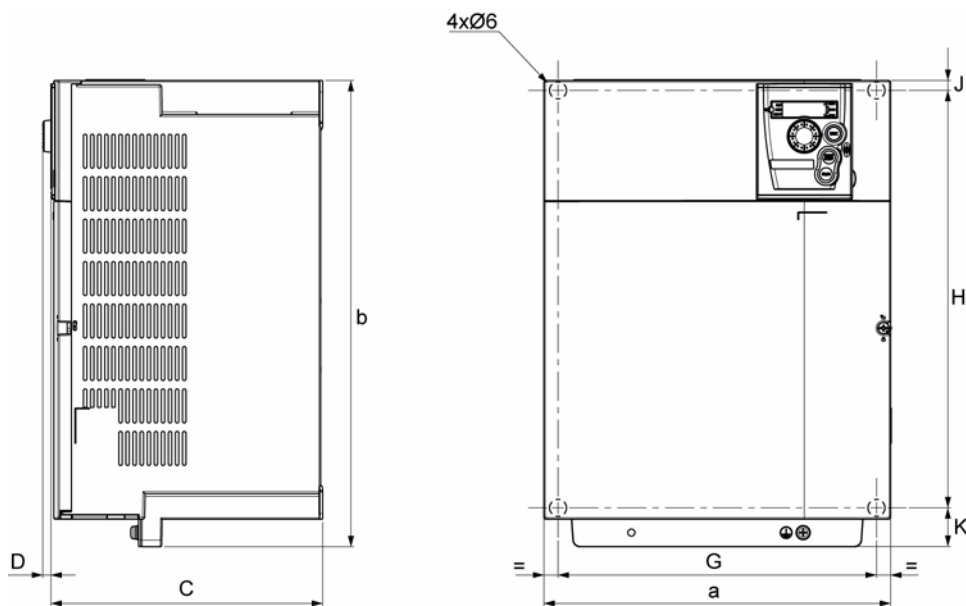

ATV312H	a mm (in.)	b mm (in.)	C mm (in.)	D mm (in.)	G mm (in.)	H mm (in.)	J mm (in.)	K mm (in.)	Ø mm (in.)
D1●M3, D1●N4, D1●S6	245 (9.65)	329.5 (12.97)	192 (7.56)	6 (0.24)	225 (8.86)	295 (11.61)	7 (0.28)	27.5 (1.08)	4 x 6 (4x0.24)

Mounting

Mounting and temperature conditions

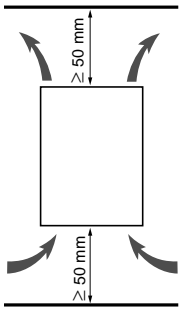

Install the unit vertically, at $\pm 10^\circ$.

Do not place it close to heating elements.

Leave sufficient free space so that the air required for cooling purposes can circulate from the bottom to the top of the unit.

Free space in front of unit: 10 mm (0.39 in.) minimum.

When IP20 protection is adequate, we recommend that the vent cover on the top of the drive be removed, as shown below.

Removing the vent cover

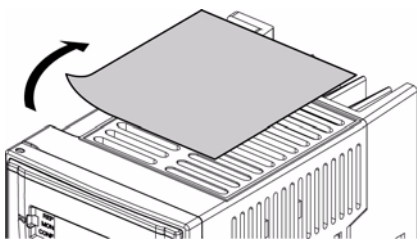

Example ATV312HU11M3

Mounting types

3 types of mounting are possible:

Type A mounting:

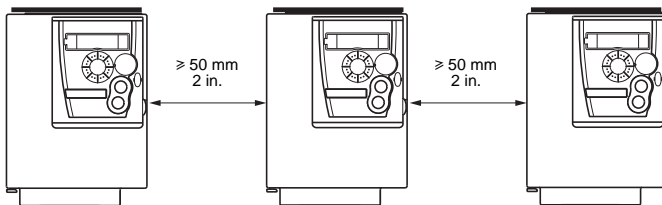

Free space ≥ 50 mm (2 in.) on each side, with vent cover fitted. Mounting type A is suitable for drive operation at surrounding air temperature less or equal to 50°C (122°F).

Type B mounting:

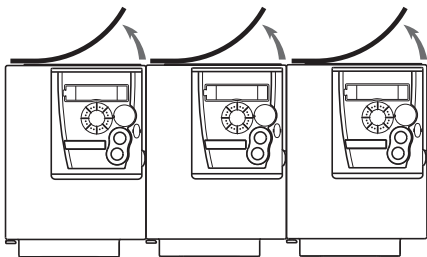

Drives mounted side-by-side, vent cover should be removed (the degree of protection becomes IP20).

Type C mounting:

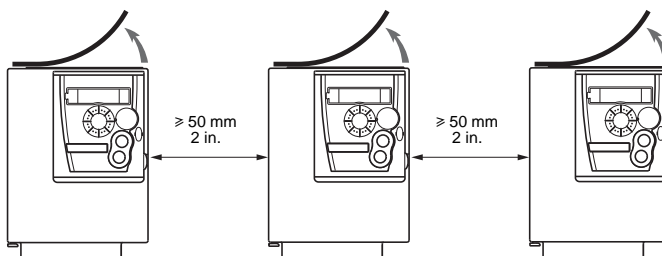

Free space ≥ 50 mm (2 in.) on each side. Vent cover should be removed for operation at surrounding air temperature above 50°C (122°F). The degree of protection becomes IP20

Note: For switching frequencies above 4 kHz and derating conditions, please refer to the derating curves for guidelines.

Mounting (continued)

Derating curves

Derating curves for the drive current I_n as a function of the temperature, switching frequency and type of mounting.

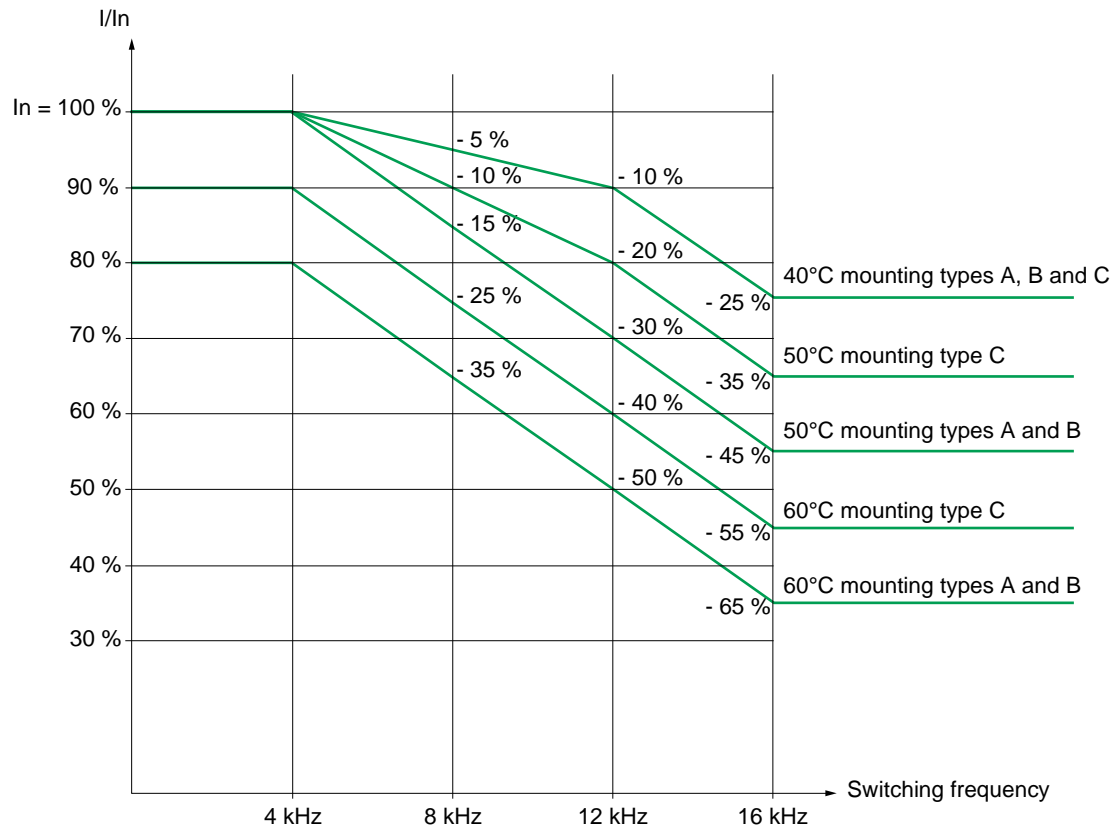

For intermediate temperatures (e.g. 55°C), interpolate between 2 curves.

Flow of air

If you are installing the drives in enclosures, make provision for a flow of air at least equal to the value given in the table below for each drive.

ATV312H	Flow rate	
	m ³ /hour	ft ³ /min
018M2, 037M2, 055M2, 018M3, 037M3, 055M3, 037N4, 055N4, 075N4, U11N4 075S6, U15S6	18	11
075M2, U11M2, U15M2 075M3, U11M3, U15M3 U15N4, U22N4 U22S6, U40S6	33	19
U22M2, U22M3, U30M3, U40M3 U30N4, U40N4 U55S6, U75S6	93	55
U55M3 U55N4, U75N4 D11S6	102	60
U75M3, D11M3, D11N4, D15N4 D15S6	168	99
D15M3	216	127

Mounting (continued)

Installing the EMC plates

EMC mounting plate: Supplied with the drive

Fix the EMC equipotentiality mounting plate to the holes in the ATV312 heatsink using the 2 screws supplied, as shown in the drawings below.

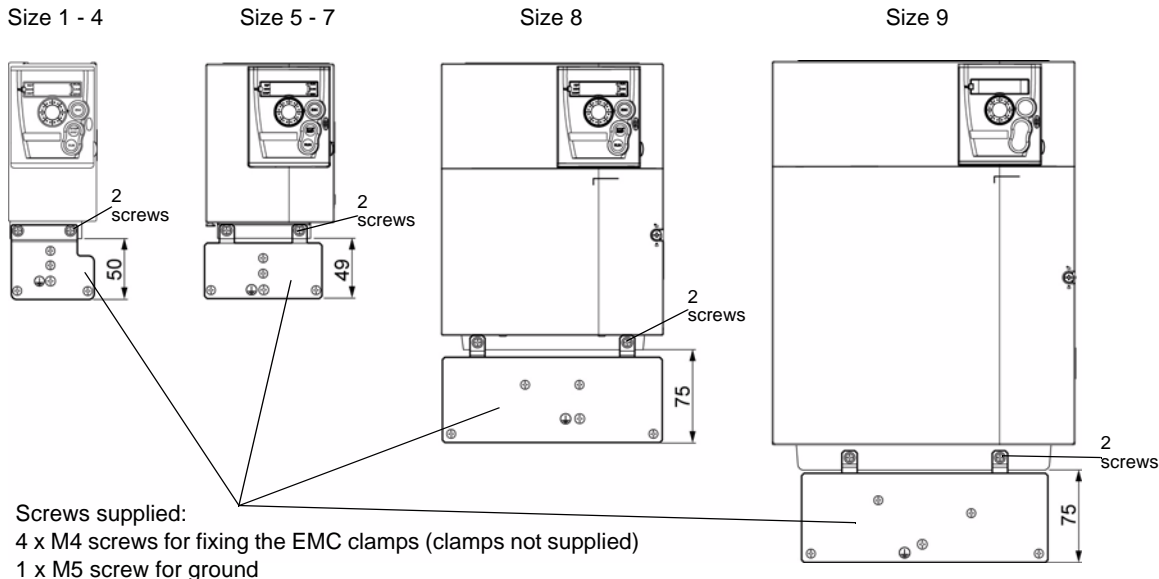

ATV312H	Size
018M3, 037M3	1
055M3, 075M3	2
018M2, 037M2	3
055M2, 075M2	4
U11M3, U15M3	5
U11M2, U15M2, U22M3, 037N4, 055N4, 075N4, U11N4, U15N4, 075S6, U15S6	6

ATV312H	Size
U22M2, U30M3, U40M3, U22N4, U30N4, U40N4, U22S6, U40S6	7
U55M3, U75M3, U55N4, U75N4, U55S6, U75S6	8
D11M3, D15M3, D11N4, D15N4, D11S6, D15S6	9

Bus voltage measurement procedure

⚠ DANGER

HAZARD OF ELECTRIC SHOCK, EXPLOSION, OR ARC FLASH

Read and understand the precautions in "Before you begin" page 5 before performing this procedure.

Failure to follow these instructions will result in death or serious injury.

The DC bus voltage can exceed 933 Vdc. Use a properly rated voltage-sensing device when performing this procedure. To measure the DC bus voltage:

1. Disconnect all power.
2. Wait 15 minutes to allow the DC bus to discharge.
3. Measure the voltage of the DC bus between the PA/+ and PC/- terminals to ensure that the voltage is less than 42 Vdc.
4. If the DC bus capacitors do not discharge completely, contact your local Schneider Electric representative. Do not repair or operate the drive.

Wiring

Recommendations

Power and circuit protection

The drive must be grounded to conform with the regulations concerning high leakage currents (over 3.5 mA).

Where local and national codes require upstream protection by means of a residual current device, use a type A device for single-phase drives and a type B device for three-phase drives as defined in the IEC Standard 60755.

Choose a suitable model integrating:

- High frequency current filtering,
- A time delay that helps to prevent tripping caused by the load from stray capacitance on power-up.
The time delay is not possible for 30 mA devices; in this case, choose devices with immunity against nuisance tripping.

If the installation includes several drives, provide one "residual current device" per drive.

Keep the power cables separate from circuits in the installation with low-level signals (detectors, PLCs, measuring apparatus, video, telephone).

If you are using cables longer than 50 m (164 ft) between the drive and the motor, add output filters (please refer to the catalogue).

Control

Keep the control circuits away from the power cables. For control and speed reference circuits, we recommend using shielded twisted cables with a pitch of between 25 and 50 mm (1 and 2 in.), connecting the shielding to ground at each end.

Equipment Grounding

Ground the drive according to local and national code requirements. A minimum wire size of 10 mm² (6 AWG) may be required to meet standards limiting leakage current.

⚠ DANGER

HAZARD OF ELECTRIC SHOCK, EXPLOSION, OR ARC FLASH

- The drive panel must be properly grounded before power is applied.
- Use the provided ground connecting point as shown in the figure below.

Failure to follow these instructions will result in death or serious injury.

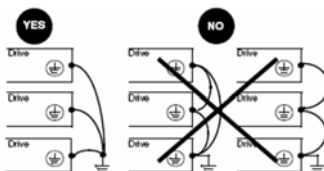

- Ensure that the resistance of the ground is one ohm or less.
- When grounding several drives, you must connect each one directly, as shown in the figure to the left.
- Do not loop the ground cables or connect them in series.

⚠ WARNING

IMPROPER WIRING PRACTICES

- The ATV312 drive will be damaged if input line voltage is applied to the output terminals (U/T1,V/T2,W/T3).
- Check the power connections before energizing the ATV312 drive.
- If replacing another drive, verify that all wiring connections to the ATV312 drive comply with wiring instructions in this manual page [29](#).

Failure to follow these instructions can result in death, serious injury, or equipment damage.

⚠ WARNING

INADEQUATE OVERCURRENT PROTECTION

- Overcurrent protective devices must be properly coordinated.
- The Canadian Electrical Code and the National Electrical Code require branch circuit protection. Use the fuses recommended in the installation manual.
- Do not connect the drive to a power feeder whose short-circuit capacity exceeds the drive short-circuit current rating listed in this manual page [29](#).

Failure to follow these instructions can result in death, serious injury, or equipment damage.

General wiring diagram

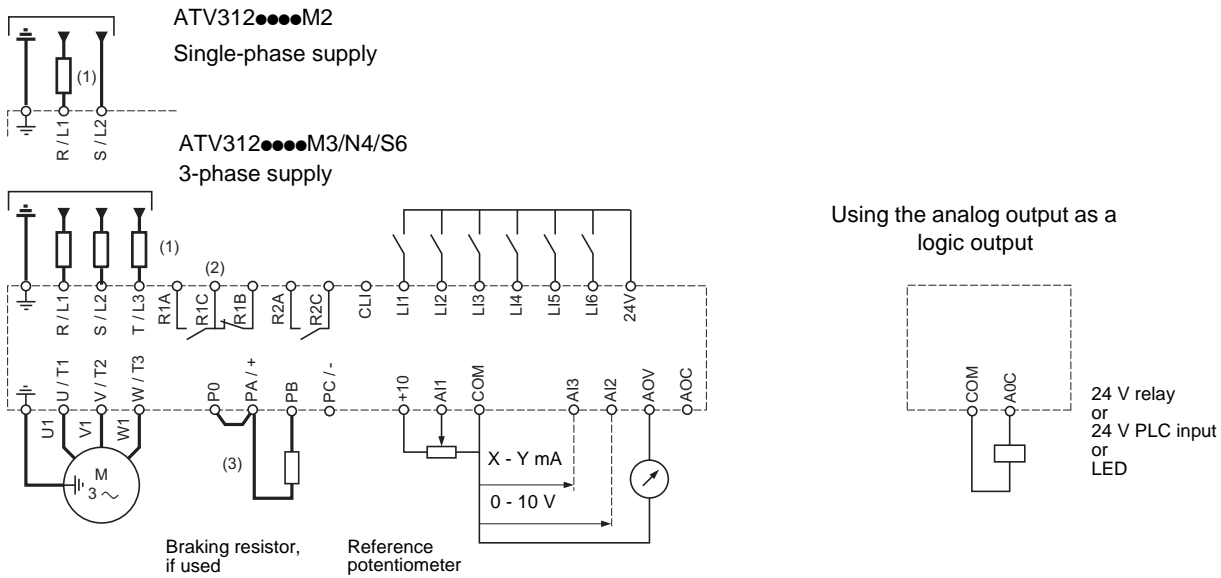

- (1) Line choke, if used (single phase or 3-phase)
- (2) Fault relay contacts, for remote indication of the drive status
- (3) If a braking resistor is connected, set [\[Dec ramp adapt.\] \(brA\)](#) parameter to yes (refer to the programming manual).

Note 1: Use interference suppressors on all inductive circuits near the drive or coupled to the same circuit (relays, contactors, solenoid valves, etc).

Note 2: This diagram is for the standard ATV312 products. Optional communication cards may change the control wiring of the product. Please see the associated documentation for the option cards for details.

Choice of associated components:

Please refer to the catalogue.

Logic input switch

This switch (1) assigns the link to 0V, 24 V or "floating":

Using volt-free contacts

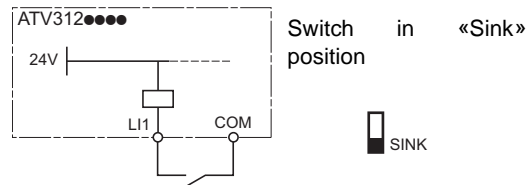
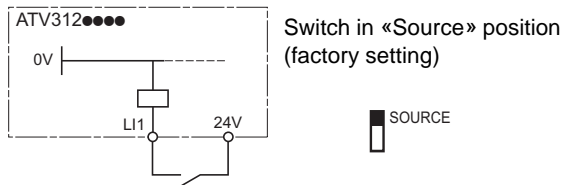

Using PLC transistor output

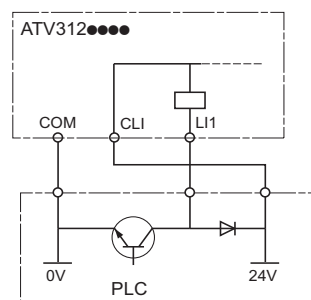
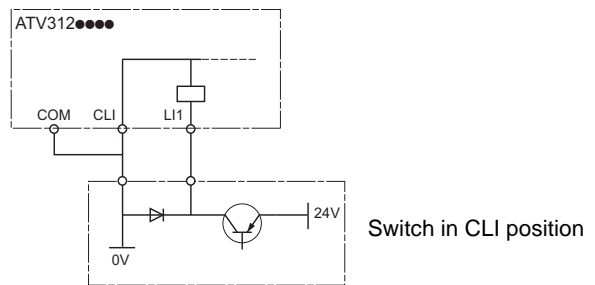

(1) See page 24 to locate the switch on the terminal board.

⚠ DANGER

UNINTENDED EQUIPMENT OPERATION

- Prevent accidental grounding of logic inputs configured for sink logic. Accidental grounding can result in unintended activation of drive functions.
- Protect the signal conductors against damage that could result in unintentional conductor grounding.
- Follow NFPA 79 and EN 60204 guidelines for proper control circuit grounding practices.

Failure to follow these instructions will result in death or serious injury.

Power terminals

Access to the power terminals

To access the terminals, open the cover as shown in the example below.

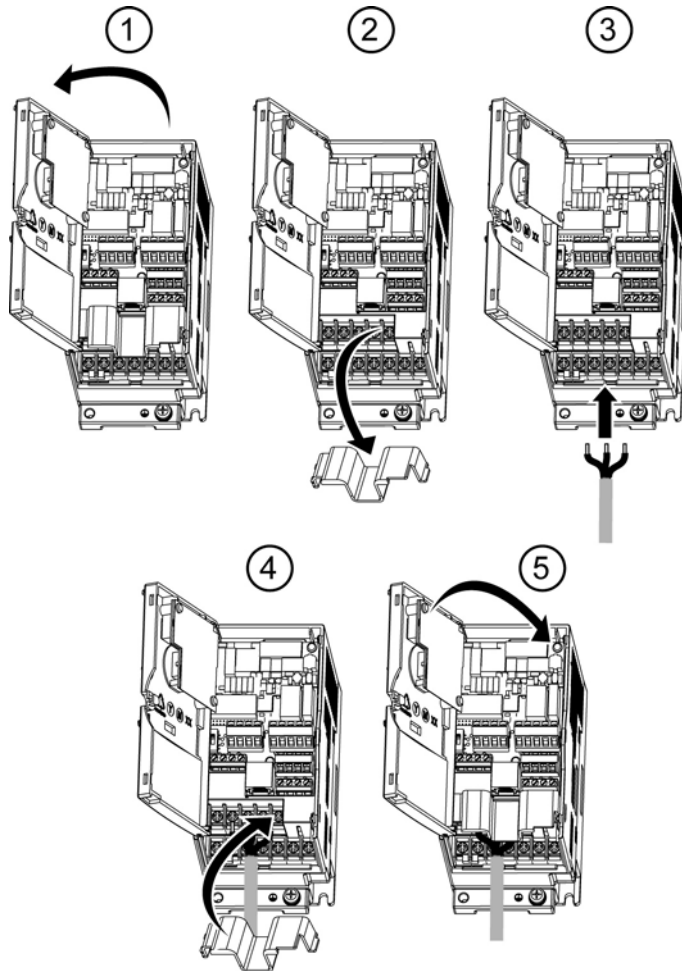

⚠ DANGER

HAZARD OF ELECTRIC SHOCK, EXPLOSION, OR ARC FLASH.

Replace the cover plate on the terminals and close the door before applying power.

Failure to follow these instructions will result in death or serious injury.

Wiring (continued)

Functions of the power terminals

Terminal	Function	For Altivar 312
⏚	Ground terminal	All ratings
R/L1 - S/L2	Power supply	ATV312●●●●M2
R/L1 - S/L2 - T/L3		ATV312●●●●M3 ATV312●●●●N4 ATV312●●●●S6
PO	DC bus + polarity	All ratings
PA/+	Output to braking resistor (+ polarity)	All ratings
PB	Output to braking resistor	All ratings
PC/-	DC bus - polarity	All ratings
U/T1 - V/T2 - W/T3	Outputs to the motor	All ratings

Arrangement and characteristics of the power terminals

CAUTION

RISK OF DAMAGE TO THE DRIVE

- Never remove the link between PO and PA/+.
- The PO and PA/+ terminal screws must always be fully tightened as a high current flows through the link.

Failure to follow these instructions can result in equipment damage

ATV312H 018M3 ... 075M3

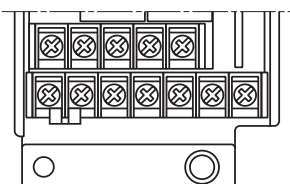

⏚	⏚	R/L1	S/L2	T/L3
P0	PA/+	PB	PC/-	U/T1 V/T2 W/T3

ATV312H	Applicable wire size (1)	Recommended wire size (2)	Tightening torque
	mm ² (AWG)	mm ² (AWG)	N·m (lb.in)
018M3, 037M3 055M3, 075M3	2.5 to 6 (14 to 10)	2.5 (14)	0.8 (7.1)

ATV312H 018M2 ...075M2

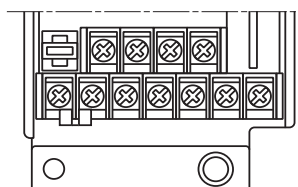

⏚	⏚	R/L1	S/L2	
P0	PA/+	PB	PC/-	U/T1 V/T2 W/T3

ATV312H	Applicable wire size (1)	Recommended wire size (2)	Tightening torque
	mm ² (AWG)	mm ² (AWG)	N·m (lb.in)
018M2, 037M2 055M2, 075M2	2.5 to 6 (14 to 10)	2.5 (14)	0.8 (7.1)

- (1) The value in bold corresponds to the minimum wire gauge to permit secureness.
 (2) 75°C (167 °F) copper cable (minimum wire size for rated use).

Wiring (continued)

ATV312H U11M3 ...U40M3 ATV312H 037N4 ... U40N4 ATV312H 075S6 ... U40S6

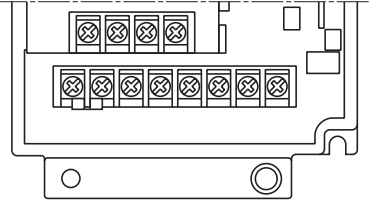

⊥	R/L1	S/L2	T/L3									
	P0	PA+	PB	PC-	U/T1	V/T2	W/T3	⊥				

ATV312H	Applicable wire size (1) mm ² (AWG)	Recommended wire size (2) mm ² (AWG)	Tightening torque N·m (lb.in)
U11M3, U15M3 037N4, 055N4, 075N4, U11N4, U15N4 075S6, U15S6	2.5 to 6 (14 to 10)	2.5 (14)	0.8 (7.1)
U22M3	2.5 to 6 (12 to 10)	3.5 (12)	1.2 (10.7)
U30M3, U40M3	2.5 to 6 (14 to 10)	6 (10)	1.2 (10.7)
U22N4, U30N4 U22S6, U40S6	2.5 to 6 (14 to 10)	2.5 (14)	1.2 (10.7)
U40N4	4 to 6 (12 to 10)	4 (12)	1.2 (10.7)

ATV312H U11M2 ... U22M2

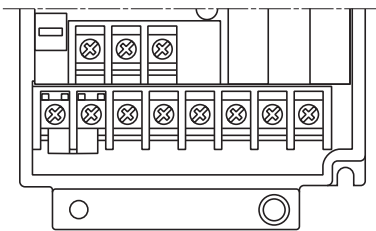

⊥	R/L1	S/L2										
	P0	PA+	PB	PC-	U/T1	V/T2	W/T3	⊥				

ATV312H	Applicable wire size (1) mm ² (AWG)	Recommended wire size (2) mm ² (AWG)	Tightening torque N·m (lb.in)
U11M2, U15M2	2.5 to 6 (12 to 10)	3.5 (12)	1.2 (10.7)
U22M2	2.5 to 6 (14 to 10)	6 (10)	1.2 (10.7)

ATV312H U55M3, U75M3 ATV312H U55N4, U75N4 ATV312H U55S6, U75S6

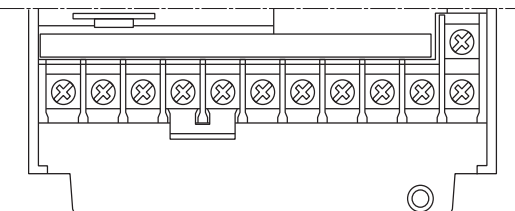

												⊥
R/L1	S/L2	T/L3	P0	PA+	PB	PC-	U/T1	V/T2	W/T3	⊥		

ATV312H	Applicable wire size (1) mm ² (AWG)	Recommended wire size (2) mm ² (AWG)	Tightening torque N·m (lb.in)
U55M3	10 to 16 (8 to 6)	10 (8)	2.5 (22.3)
U75M3	10 to 16 (8 to 6)	16 (6)	2.5 (22.3)
U55N4, U55S6, U75S6	4 to 6 (12 to 10)	6 (10)	2.5 (22.3)
U75N4	10 to 16 (8 to 6)	16 (8)	2.5 (22.3)

(1) The value in bold corresponds to the minimum wire gauge to permit secureness.

(2) 75°C (167 °F) copper cable (minimum wire size for rated use).

Wiring (continued)

ATV312H D11M3, D15M3
 ATV312H D11N4, D15N4
 ATV312H D11S6, D15S6

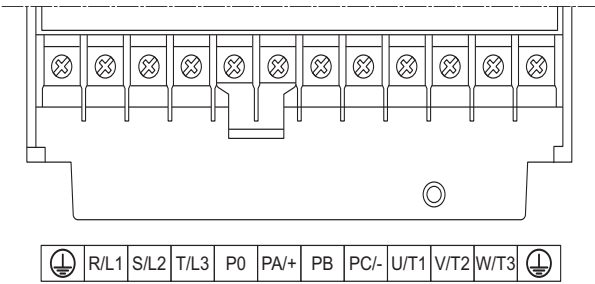

ATV312H	Applicable wire size (1) mm ² (AWG)	Recommended wire size (2) mm ² (AWG)	Tightening torque N·m (lb.in)
D11M3	10 to 25 (8 to 4)	25 (4)	4.5 (40.1)
D15M3, D15N4	10 to 25 (8 to 4)	16 (6)	4.5 (40.1)
D11N4, D11S6, D15S6	10 to 25 (8 to 4)	10 (8)	4.5 (40.1)

- (1) The value in bold corresponds to the minimum wire gauge to permit secureness.
 (2) 75°C (167 °F) copper cable (minimum wire size for rated use).

Control terminals

Access to the control terminals

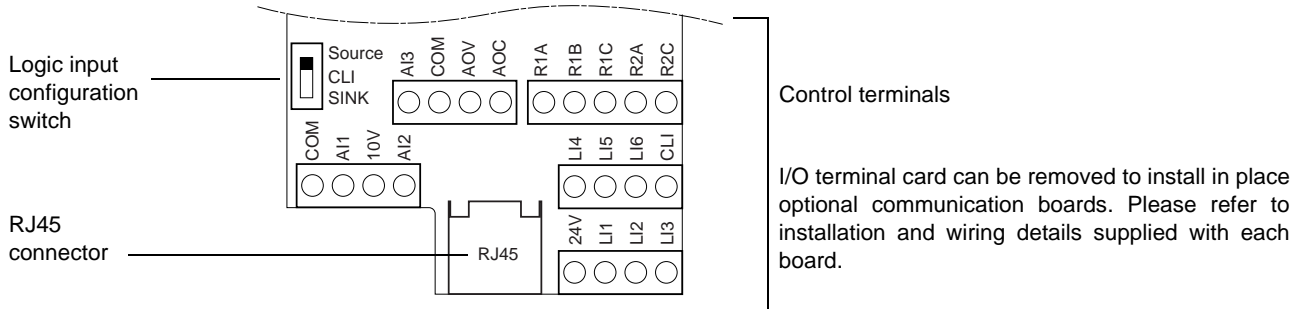
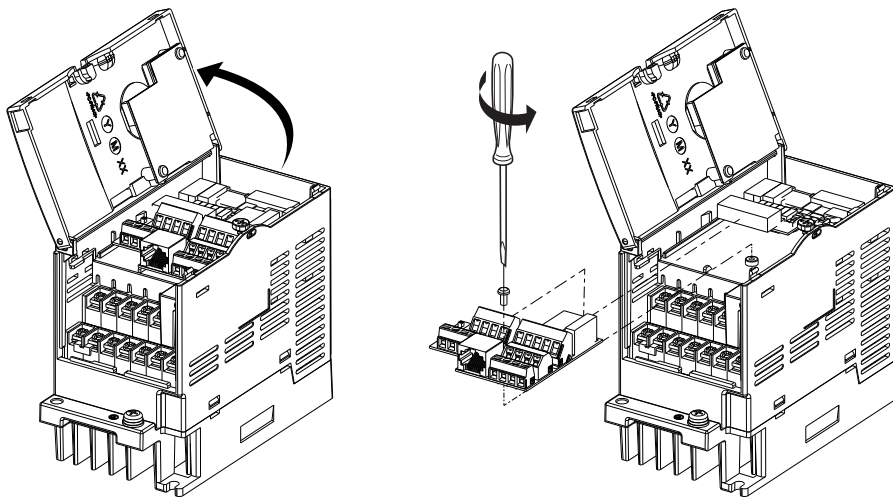

⚠ DANGER

UNINTENDED EQUIPMENT OPERATION

- Do not plug or unplug the terminal board while drive is powered.
- Check the tightening of the fixing screw after any manipulation on the terminal board.

Failure to follow these instructions will result in death or serious injury.

⚠ DANGER

HAZARD OF ELECTRIC SHOCK, EXPLOSION, OR ARC FLASH

Do not touch the terminal board before :

- removing power on the drive,
- removing any voltage on input and output terminals.

Failure to follow these instructions will result in death or serious injury.

Arrangement of the control terminals

ATV312 Control terminals	Applicable wire size (1) mm ² (AWG)	Tightening torque (2) N·m (lb.in)
R1A, R1B, R1C, R2A, R2C	0.75 to 2.5 (18 to 14)	0.5 to 0.6 (4.4 to 5.3)
Other terminals	0.14 to 2.5 (26 to 16)	

(1) The value in bold corresponds to the minimum wire gauge to permit secureness.
 (2) Recommended to maximum value.

Characteristics and functions of the control terminals

Terminal	Function	Electrical characteristics
R1A R1B R1C	Common point C/O contact (R1C) of programmable relay R1	<ul style="list-style-type: none"> • Min. switching capacity: 10 mA for 5 V --- • Max. switching capacity on resistive load ($\cos \varphi = 1$ and $L/R = 0$ ms): 5 A for 250 V \sim and 30 V ---
R2A R2C	N/O contact of programmable relay R2	<ul style="list-style-type: none"> • Max. switching capacity on inductive load ($\cos \varphi = 0.4$ and $L/R = 7$ ms): 1.5 A for 250 V \sim and 30 V --- • Sampling time 8 ms • Service life: 100,000 operations at max. switching power 1,000,000 operations at min. switching power
COM	Analog I/O common	0 V
AI1	Analog input voltage	Analog input 0 + 10 V (max. safe voltage 30 V) <ul style="list-style-type: none"> • Impedance 30 kΩ • Resolution 0.01 V, 10-bit converter • Precision $\pm 4.3\%$, linearity $\pm 0.2\%$, of max. value • Sampling time 8 ms • Operation with shielded cable 100 m max.
10 V	Power supply for reference potentiometer	+10 V (+ 8% - 0%), 10 mA max, protected against short-circuits and overloads
AI2	Analog input voltage	Bipolar analog input 0 \pm 10 V (max. safe voltage ± 30 V) The + or - polarity of the voltage on AI2 affects the direction of the setpoint and therefore the direction of operation. <ul style="list-style-type: none"> • Impedance 30 kΩ • Resolution 0.01 V, 10-bit + sign converter • Precision $\pm 4.3\%$, linearity $\pm 0.2\%$, of max. value • Sampling time 8 ms • Operation with shielded cable 100 m max.
AI3	Analog input current	Analog input X - Y mA. X and Y can be programmed from 0 to 20 mA <ul style="list-style-type: none"> • Impedance 250 Ω • Resolution 0.02 mA, 10-bit converter • Precision $\pm 4.3\%$, linearity $\pm 0.2\%$, of max. value • Sampling time 8 ms
COM	Analog I/O common	0 V
AOV or AOC	Analog output voltage AOV or Analog output current AOC or Logic output voltage AOC AOV or AOC can be assigned (either, but not both)	Analog output 0 to 10 V, min. load impedance 470 Ω or Analog output X - Y mA. X and Y can be programmed from 0 to 20 mA, max. load impedance 800 Ω <ul style="list-style-type: none"> • Resolution 8 bits (1) • Precision $\pm 1\%$ (1) • Linearity $\pm 0.2\%$ (1) • Sampling time 8 ms This analog output can be configured as a 24 V logic output on AOC, min. load impedance 1.2 k Ω . (1) Characteristics of digital/analog converter.
24 V	Logic input power supply	+ 24 V protected against short-circuits and overloads, min. 19 V, max. 30 V Max. customer current available 100 mA
LI1 LI2 LI3 LI4 LI5 LI6	Logic inputs	Programmable logic inputs <ul style="list-style-type: none"> • + 24 V power supply (max. 30 V) • Impedance 3.5 kΩ • State 0 if < 5 V, state 1 if > 11 V (voltage difference between LI- and CLI) • Sampling time 4 ms
CLI	Logic input common	See page 19 .
RJ45	Communication port	Connection for SoMove software, Modbus and CANopen network, remote display, configuration loader tools,

Electromagnetic compatibility (EMC)

IMPORTANT: The high frequency equipotential ground connection between the drive, motor, and cable shielding does not eliminate the need to connect the ground (PE) conductors (green-yellow) to the appropriate terminals on each unit.

Principle and precautions

- Grounds between the drive, motor, and cable shielding must have high frequency equipotentiality.
- When using shielded cable for the motor, use a 4-conductor cable so that one wire will be the ground connection between the motor and the drive. Size of the ground conductor must be selected in compliance with local and national codes. The shield can then be grounded at both ends. Metal ducting or conduit can be used for part or all of the shielding length, provided there is no break in continuity.
- When using shielded cable for Dynamic Brake (DB) resistors, use a 3-conductor cable so that one wire will be the ground connection between the DB resistor assembly and the drive. The size of the ground conductor must be selected in compliance with local and national codes. The shield can then be grounded at both ends. Metal ducting or conduit can be used for part or all of the shielding length, provided there is no break in continuity.
- When using shielded cable for control signals, if the cable is connecting equipment that is close together and the grounds are bonded together, then both ends of the shield can be grounded. If the cable is connected to equipment that may have a different ground potential, then ground the shield at one end only to prevent large currents from flowing in the shield. The shield on the ungrounded end may be tied to ground with a capacitor (for example: 10 nF, 100 V or higher) in order to provide a path for the higher frequency noise. Keep the control circuits away from the power circuits. For control and speed reference circuits, we recommend using shielded twisted cables with a pitch of between 25 and 50 mm (1 and 2 in.) Keep the control circuits away from the power circuits. For control and speed reference circuits, we recommend using shielded twisted cables with a pitch of between 25 and 50 mm (1 and 2 in.)
- Ensure maximum separation between the power supply cable (line supply) and the motor cable.
- The motor cables must be at least 0.5 m (20 in.) long.
- Do not use surge arresters or power factor correction capacitors on the variable speed drive output.
- If using an additional input filter, it should be mounted as close as possible to the drive and connected directly to the line supply via an unshielded cable. Link 1 on the drive is via the filter output cable.
- For installation of the optional EMC plate and instructions for meeting IEC 61800-3 standard, refer to the section entitled "Installing the EMC plates" and the instructions provided with the EMC plates.

DANGER

HAZARD OF ELECTRIC SHOCK, EXPLOSION OR ARC FLASH

- Do not expose cable shielding except where connected to ground at the metal cable glands and underneath the grounding clamps.
- Ensure that there is no risk of the shielding coming into contact with live components.

Failure to follow these instructions will result in death or serious injury.

Optional EMC plate installation diagram and instructions (examples)

Installation depends on the drive size. The table below gives the size according to the reference.

Size 1	Size 2	Size 3	Size 4	Size 5	Size 6	Size 7	Size 8	Size 9
H018M3, H037M3	H055M3, H075M3	H018M2, H037M2	H055M2, H075M2	HU11M3, HU15M3	HU11M2, HU15M2, HU22M3, H037N4, H055N4, H075N4, HU11N4, HU15N4, H075S6, HU15S6	HU22M2, HU30M3, HU40M3, HU22N4, HU30N4, HU40N4, HU22S6, HU40S6	HU55M3, HU75M3, HU55N4, HU75N4, HU55S6, HU75S6	HD11M3, HD15M3, HD11N4, HD15N4, HD11S6, HD15S6

Sizes 1 to 4

Size 5 to 7

Size 8

Size 9

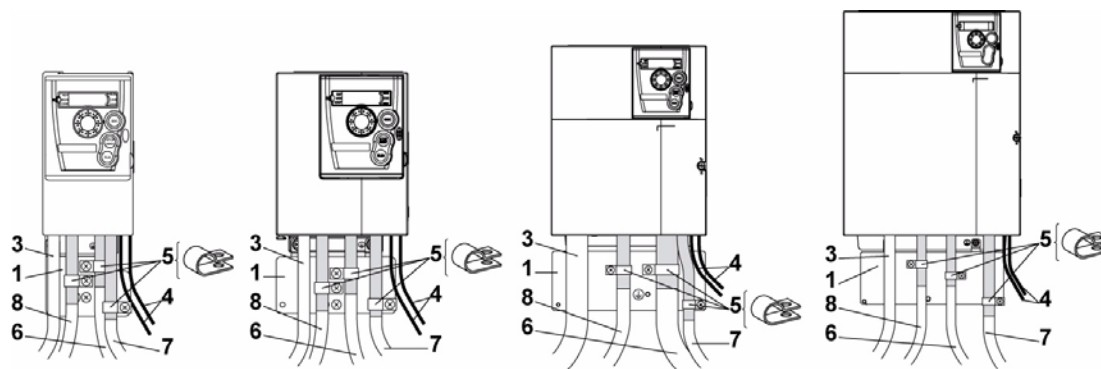

1. EMC plate supplied with the drive, to be installed as indicated on the diagram.
2. Altivar 312
3. Non-shielded power supply wires or cable
4. Non-shielded wires for relay contacts
5. Attach and ground the shielding of cables 6, 7 and 8 as close as possible to the drive:
 - Strip the shielding.
 - Use stainless steel cable clamps of an appropriate size on the parts from which the shielding has been stripped, to attach them to the plate 1.

The shielding must be clamped tightly to the metal plate to improve electrical contact.
6. Shielded cable for motor connection with shielding connected to ground at both ends.

The shielding must be continuous and intermediate terminals must be in EMC shielded metal boxes.

For 0.18 to 1.5 kW drives, if the switching frequency is higher than 12 kHz, use cables with low linear capacitance: max. 130 pF (picoFarads) per meter.
7. Shielded cable for connecting the control/signalling wiring.

For applications requiring several conductors, use cables with a small cross-section (0.5 mm², 20 AWG).

The shielding must be connected to ground at both ends. The shielding must be continuous and intermediate terminals must be in EMC shielded metal boxes.
8. Shielded cable for connecting braking resistor (if used).

The shielding must be continuous and intermediate terminals must be in EMC shielded metal boxes.

Note:

- If using an additional input filter, it should be mounted under the drive and connected directly to the line supply via an unshielded cable. Link 3 on the drive is then via the filter output cable.
- The HF equipotential ground connection between the drive, motor and cable shielding does not remove the need to connect the PE ground conductors (green-yellow) to the appropriate terminals on each unit.

Operation on an IT system

IT system: Isolated or impedance earthed neutral.

ATV312●●●●M2 and ATV312●●●●N4 drives have a built-in EMC filter. As a result they exhibit leakage current to ground. If the leakage current creates compatibility problems with your installation (residual current device or other), then you can reduce the leakage current by opening the IT jumper. In this configuration EMC compliance is not guaranteed.

Use a permanent insulation monitor compatible with non-linear loads (for example Merlin Gerin type XM200).

ATV312H 018M2 to U22M2 and ATV312H 037N4 to U40N4:

Pull out the jumper on the left of the ground terminal as illustrated below.

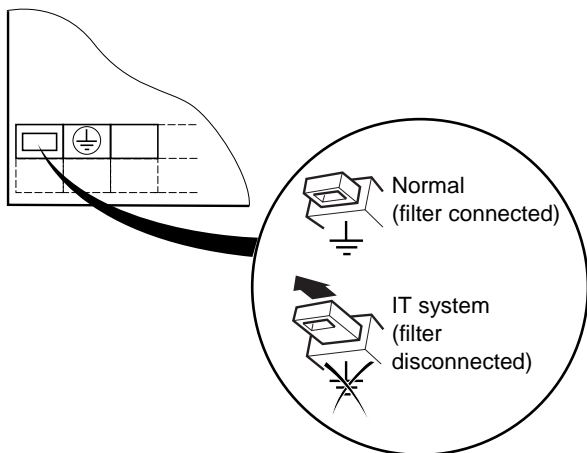

ATV312H U55N4 to D15N4:

Move the cable tag on the top left of the power terminals as illustrated below (example: ATV312HU55N4):

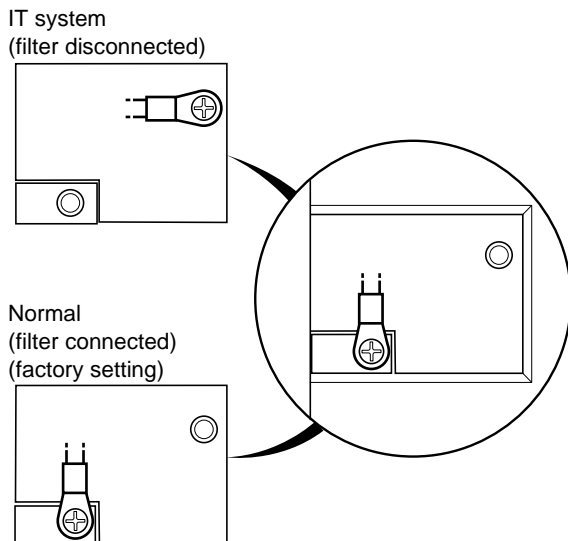

Check list

Read carefully the safety information in programming, installation, simplified manuals and the catalogue. Before starting up the drive, please check the following points regarding mechanical and electrical installations, then use and run the drive.
For complete documentation, refer to www.schneider-electric.com.

1. Mechanical installation

- For drive mounting types and recommendations on the ambient temperature (see the Mounting instructions on page [14](#)).
- Mount the drive vertically as specified (see the Mounting instructions on page [14](#)).
- The use of the drive must be in agreement with the environments defined by the standard 60721-3-3 and according to the levels defined in the catalogue.
- Mount the options required for your application (see catalogue).

2. Electrical installation

- Connect the drive to the ground (see Equipment Grounding on page [17](#)).
- Ensure that the input power voltage corresponds to the drive nominal voltage and connect the line supply as shown on the drawing on page [18](#).
- Ensure to use appropriate input power fuses and circuit breaker.
- Wire the control terminals as required (see Control terminals on page [24](#)). Separate the power cable and the control cable according to EMC compatibility rules.
- The range ATV312●●●●M2 and ATV312●●●●N4 integrates EMC filter. The leakage current can be reduced using the IT jumper as explained in the paragraph Operating on an IT system on page [28](#).
- Ensure that motor connections correspond to the voltage (star, delta).

3. Use and run the drive (see programming manual)

- Start the drive and you will see [\[Standard mot. freq\] \(bFr\)](#) at the first power on. Check that the frequency defined by the frequency [b F r](#) (the factory setting is 50 Hz) is in accordance with the frequency of the motor.
- On first power-up parameters [\[Ref.1 channel\] \(Fr1\)](#) and [\[2/3 wire control\] \(tCC\)](#) appear after [b F r](#). These parameters should be set if you want to control the drive locally, see page «How to control the drive locally» in the programming manual.
- On subsequent power-up, [r d y](#) will be displayed on the HMI.
- The [\[Restore config.\] \(FCS\)](#) function, permits you to reset the drive with factory settings.

Maintenance

Servicing

The Altivar 312 does not require any preventive maintenance. However, it is advisable to perform the following checks regularly:

- The condition and tightness of connections.
- Ensure that the temperature around the unit remains at an acceptable level and that ventilation is effective. Average service life of fans: 10 years.
- Remove any dust from the drive.
- Ensure proper fan operation.
- Physical damage to covers.

Assistance with maintenance, detected fault display

If a problem arises during setup or operation, ensure that the recommendations relating to the environment, mounting and connections have been observed.

The first fault detected is stored and displayed, flashing, on the screen: the drive locks and the status relay (R1) contact opens.

Clearing the detected fault

Disconnect the drive power supply in the event of a non-resettable fault.

Wait for the display to go off completely.

Find the cause of the detected fault and correct it.

Restore power to the drive.

The detected fault will no longer be present if its cause has been corrected.

In the event of a non resettable detected fault:

- Remove/cut the power to the drive.
- WAIT 15 MINUTES to allow the DC bus capacitors to discharge. Then follow the "Bus Voltage Measurement Procedure" page [16](#) to verify that the DC voltage is less than 42 V. The drive LEDs are not indicators of the absence of DC bus voltage.
- Find and correct the detected fault.
- Restore power to the drive to confirm the detected fault has been rectified.

Certain detected faults can be programmed for automatic restart after the cause has disappeared.

These detected faults can also be reset by cycling power to the drive or by means of a logic input or control bit.

Display menu

Use the display menu to show the status of the drive and its current values as an aid for finding the causes of detected faults.

Spares and repairs

Serviceable product: replacement of spares following the catalog.

Procedure after a long time storage

WARNING

RISK OF EXPLOSION AT THE POWER UP

The capacitors after a long time storage can have issues. Following a storage time between 2 and 3 years:

- Use one AC supply variable connected between L1, L2 and L3
- Increase AC supply voltage to have:
 - 25% of rated voltage during 30mn
 - 50% of rated voltage during 30mn
 - 75% of rated voltage during 30mn
 - 100% of rated voltage during 30mn

Failure to follow these instructions can result in death, serious injury, or equipment damage.

Recommended fuse ratings

Reference	Power rating		SC interrupt rating (from UL file)	SC withstand rating (1)	SC output interrupt rating (2)	SC enclosure containment rating	
	kW	HP	KA	KA	KA	Fuse Class J and CC	SC (3)
ATV312H018M2	0.18	0.25	1	1	22	6	not tested
ATV312H037M2	0.37	0.5	1	1	22	10	not tested
ATV312H055M2	0.55	0.75	1	1	22	10	not tested
ATV312H075M2	0.75	1	1	1	22	15	not tested
ATV312HU11M2	1.1	1.5	1	1	22	20	not tested
ATV312HU15M2	1.5	2	1	1	22	20	not tested
ATV312HU22M2	2.2	3	1	1	22	30	not tested
ATV312H018M3	0.18	0.25	5	5	22	3	22
ATV312H037M3	0.37	0.5	5	5	22	6	22
ATV312H055M3	0.55	0.75	5	5	22	10	22
ATV312H075M3	0.75	1	5	5	22	10	22
ATV312HU11M3	1.1	1.5	5	5	22	15	22
ATV312HU15M3	1.5	2	5	5	22	15	22
ATV312HU22M3	2.2	3	5	5	22	20	22
ATV312HU30M3	3	3	5	5	22	25	22
ATV312HU40M3	4	5	5	5	22	35	22
ATV312HU55M3	5.5	7.5	5	22	22	50	22
ATV312HU75M3	7.5	10	5	22	22	60	22
ATV312HD11M3	11	15	5	22	22	80	22
ATV312HD15M3	15	20	5	22	22	110	22
ATV312H037N4	0.37	0.5	5	5	22	3	100
ATV312H055N4	0.55	0.75	5	5	22	6	100
ATV312H075N4	0.75	1	5	5	22	6	100
ATV312HU11N4	1.1	1.5	5	5	22	10	100
ATV312HU15N4	1.5	2	5	5	22	10	100
ATV312HU22N4	2.2	3	5	5	22	15	100
ATV312HU30N4	3	3	5	5	22	15	100
ATV312HU40N4	4	5	5	5	22	20	100
ATV312HU55N4	5.5	7.5	5	22	22	30	100
ATV312HU75N4	7.5	10	5	22	22	35	100
ATV312HD11N4	11	15	5	22	22	50	100
ATV312HD15N4	15	20	5	22	22	70	100

(1) Product design level

(2) Output short circuit tested

(3) If line I_{sc} is greater than the values in the table, add line chokes

Recommended fuse ratings (continued)

Reference	Power rating		SC interrupt rating (from UL file)	SC withstand rating (1)	SC output interrupt rating (2)	SC enclosure containment rating	
	kW	HP	KA	KA	KA	Fuse Class J and CC	SC (3)
ATV312H075S6	0.75	1	5	5	22	6	22
ATV312HU15S6	1.5	2	5	5	22	6	22
ATV312HU22S6	2.2	3	5	5	22	10	22
ATV312HU40S6	4	5	5	5	22	15	22
ATV312HU55S6	5.5	7.5	5	22	22	20	22
ATV312HU75S6	7.5	10	5	22	22	25	22
ATV312HD11S6	11	15	5	22	22	35	22
ATV312HD15S6	15	20	5	22	22	45	22

(1) Product design level

(2) Output short circuit tested

(3) If line I_{sc} is greater than the values in the table, add line chokes

